

Price On Request Gwendolen Road, Leicester, LE5



- Immaculate three-bedroom semi-detached family home by BM Estates
- Ideal for first-time buyers, offering a warm and inviting atmosphere
- Conveniently located near schools and local amenities
- Well-lit entrance hall, front sitting room, and versatile lounge/diner
- Three generously sized bedrooms and a well-designed family bathroom
- Spacious rear garden with potential for extensions, plus off-road parking for one vehicle at the front.

BM Estates is delighted to present this immaculate three-bedroom semi-detached family residence, perfect for first-time buyers seeking a comfortable and stylish living space. Nestled in a desirable location, this property offers not only a warm and inviting atmosphere but also convenient access to nearby schools and local amenities.

Upon entering, you are greeted by a well-lit and welcoming entrance hall, setting the tone for the rest of the home. The front sitting room provides a cozy retreat, ideal for relaxation and quality family time. Move seamlessly into the rear lounge/diner, a versatile space perfect for entertaining guests or enjoying meals together. Sliding doors open to reveal a private garden, offering a serene outdoor escape.

The well-appointed kitchen is both functional and aesthetically pleasing, catering to the needs of the modern family. As you ascend to the first floor, you'll discover three generously sized bedrooms, each providing ample space for rest and relaxation. The family bathroom, thoughtfully designed, completes the upstairs living quarters.

The rear garden is a standout feature, boasting a substantial space with the potential for future extensions (subject to planning permission). Imagine creating your own outdoor oasis or expanding the living space to suit your growing needs. To the front of the property, off-road parking for a single vehicle adds a practical touch to your daily convenience.

In summary, this property offers a rare combination of comfort, convenience, and potential for future growth. Don't miss the opportunity to make this house your home – contact BM Estates today to schedule a viewing and experience the charm of this delightful family residence.

Gwendolen Road, Leicester, LE5

Front

Block paved off road parking for single vehicle and access to side storage room.

Entrance Hall

Access to sitting room, lounge/diner, cloak room and access to first floor.

Sitting Room

3.90m x 3.42m (12'10" x 11'3")

uPVC window to front elevation, fitted storage, radiator.

Lounge/Diner

3.64m x 3.42m (11'11" x 11'3")

uPVC sliding door to rear elevation, wood flooring with under floor heating.

Kitchen

1.94m x 3.74m (6'4" x 12'3")

uPVC window to rear elevation, fitted storage, fitted kitchen, tiled floor.

Landing

Access to all bedrooms and family bathroom.

Bedroom 1

3.64m x 3.41m (11'11" x 11'2")

uPVC window to rear elevation, fitted storage and radiator.

Bedroom 2

3.34m x 3.03m (10'11" x 9'11")

uPVC window to front elevation, radiator and fitted storage.

Bedroom 3

2.40m x 2.39m (7'10" x 7'10")

uPVC window to front elevation, radiator.

Family Bathroom

2.02m x 1.76m (6'8" x 5'9")

uPVC window to rear elevation, radiator, full three piece bathroom, tiled wall, tiled floor.

Garden facing home

Medium sized laid to lawn garden.

Garden

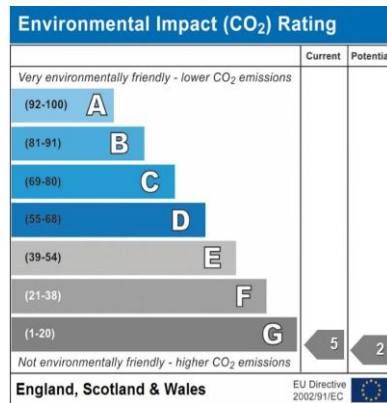
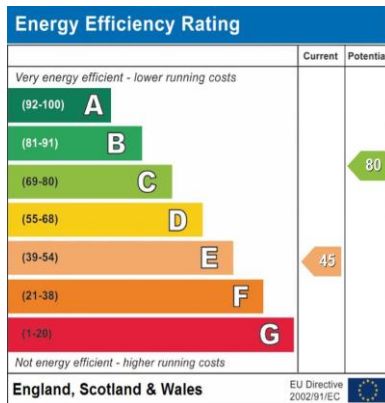





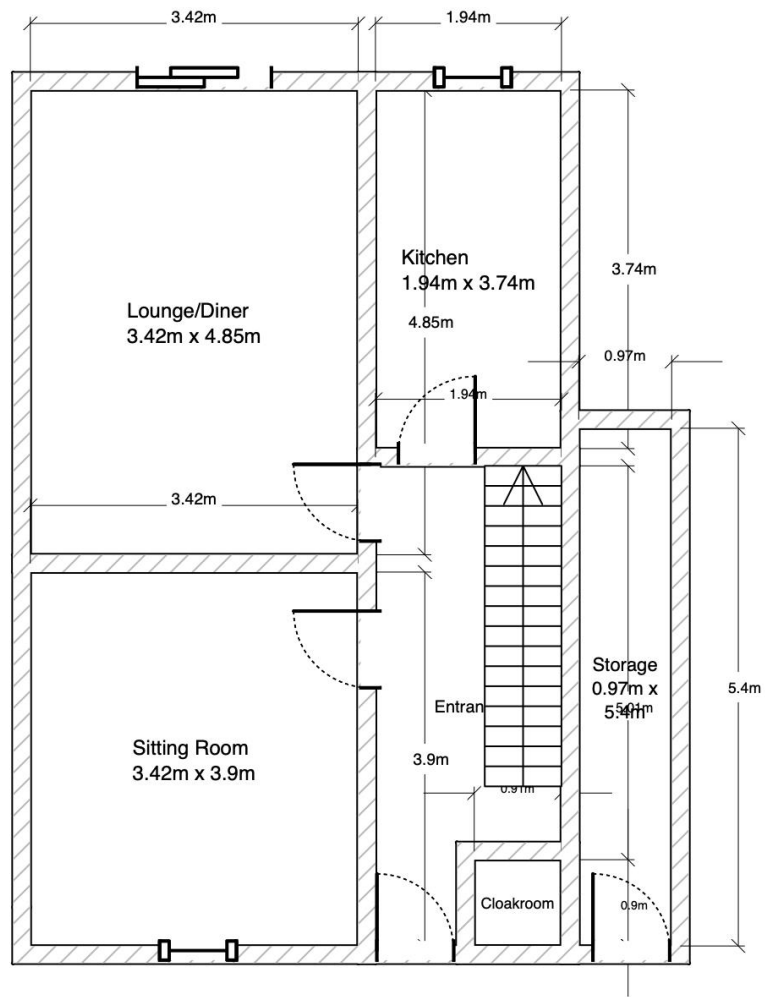

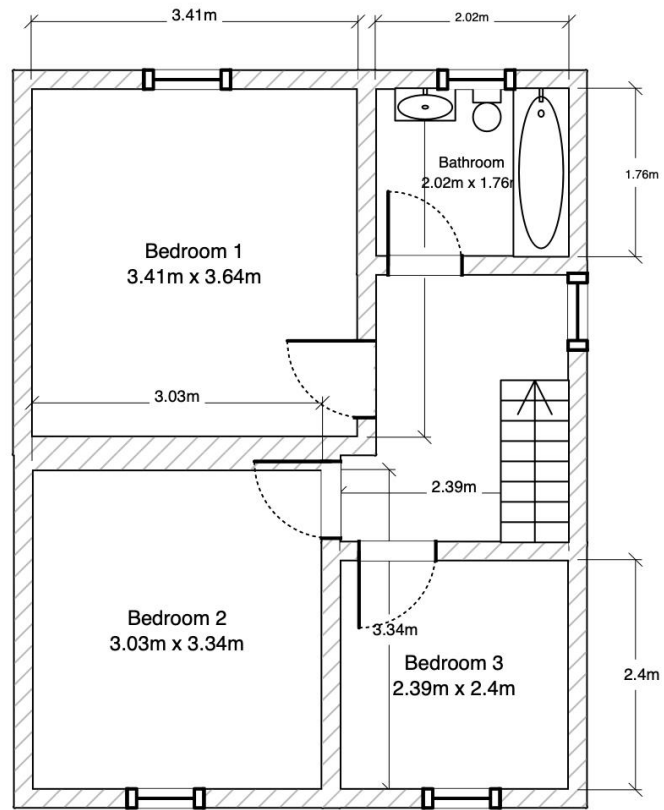

Directions

Start your journey by driving up Wakerley Road, with Goals on your left-hand side. After passing Goals, make a left turn onto Gwendolen Road. Continue driving down Gwendolen Road. As you proceed, you will notice the property on your right-hand side. Look out for our distinctive For Sale board, which will mark the location of the property. The property is conveniently situated on the right-hand side of Gwendolen Road, marked by our prominent For Sale signage.

Location

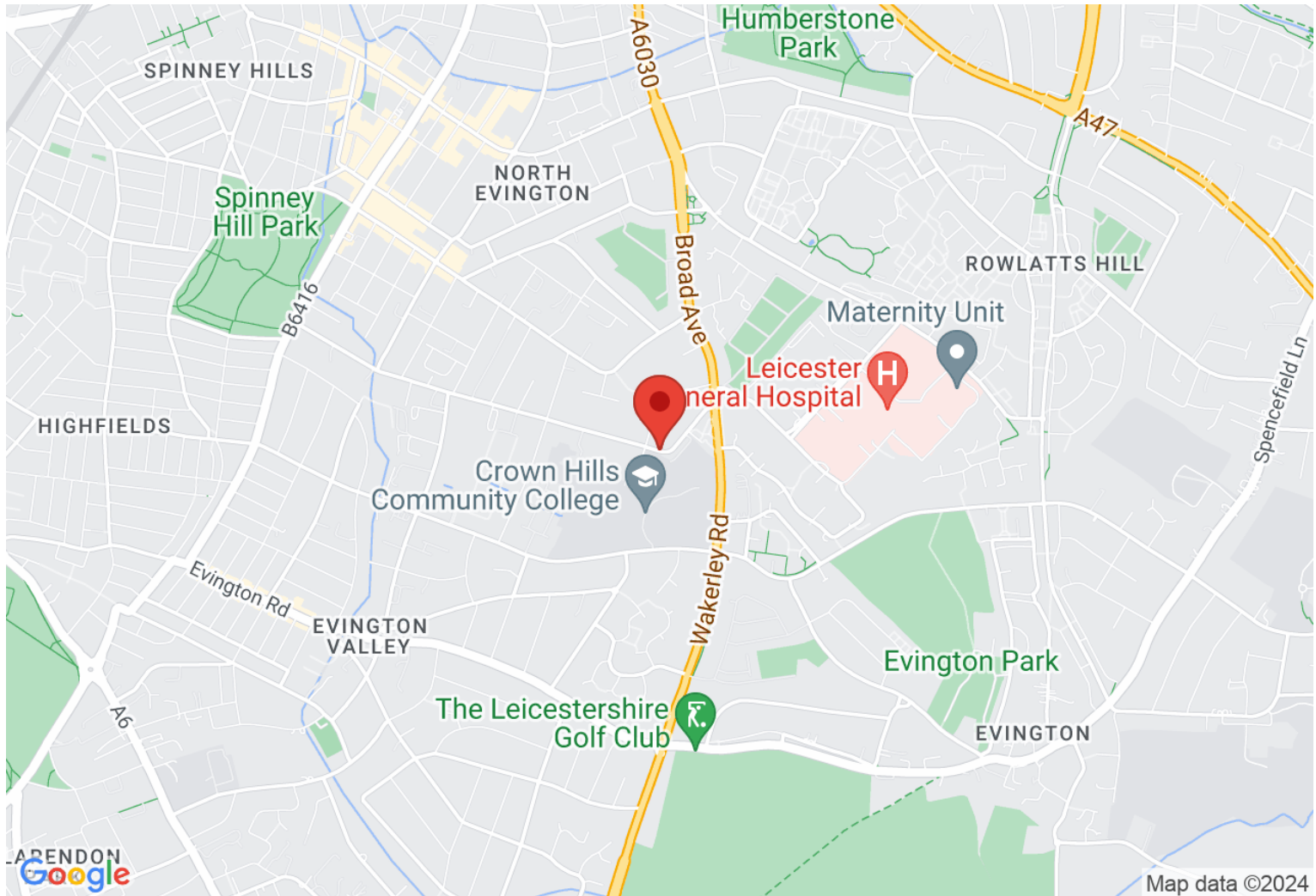

VIEWING BY APPOINTMENT WITH AGENTS BM ESTATES

312 St Saviours Road, Leicester, Leicestershire, LE5 4HJ T: 0116 273 7748 E: mines@bmestates.com W: www.bmestates.com

General: While we endeavour to make our sales particulars fair, accurate and reliable, they are only a general guide to the property and, accordingly, if there is any point which is of particular importance to you, please contact the office and we will be pleased to check the position for you, especially if you are contemplating travelling some distance to view the property.

Measurements: These approximate room sizes are only intended as general guidance. You must verify the dimensions carefully before ordering carpets or any built-in furniture.

Services: Please note we have not tested the services or any of the equipment or appliances in this property, accordingly we strongly advise prospective buyers to commission their own survey or service reports before finalizing their offer to purchase.

THESE PARTICULARS ARE ISSUED IN GOOD FAITH BUT DO NOT CONSTITUTE REPRESENTATIONS OF FACT OR FORM PART OF ANY OFFER OR CONTRACT. THE MATTERS REFERRED TO IN THESE PARTICULARS SHOULD BE INDEPENDENTLY VERIFIED BY PROSPECTIVE BUYERS OR TENANTS. NEITHER BM ESTATES NOR ANY OF ITS EMPLOYEES OR AGENTS HAS ANY AUTHORITY TO MAKE OR GIVE ANY REPRESENTATION OR WARRANTY WHATSOEVER IN RELATION TO THIS PROPERTY.

YOUR HOME IS AT RISK IF YOU DO NOT KEEP UP REPAYMENTS ON A MORTGAGE OR OTHER LOAN SECURED ON IT.

Written quotations available on request. All loans secured on property. Life assurance is usually required.